

**Access Strategy Option A**

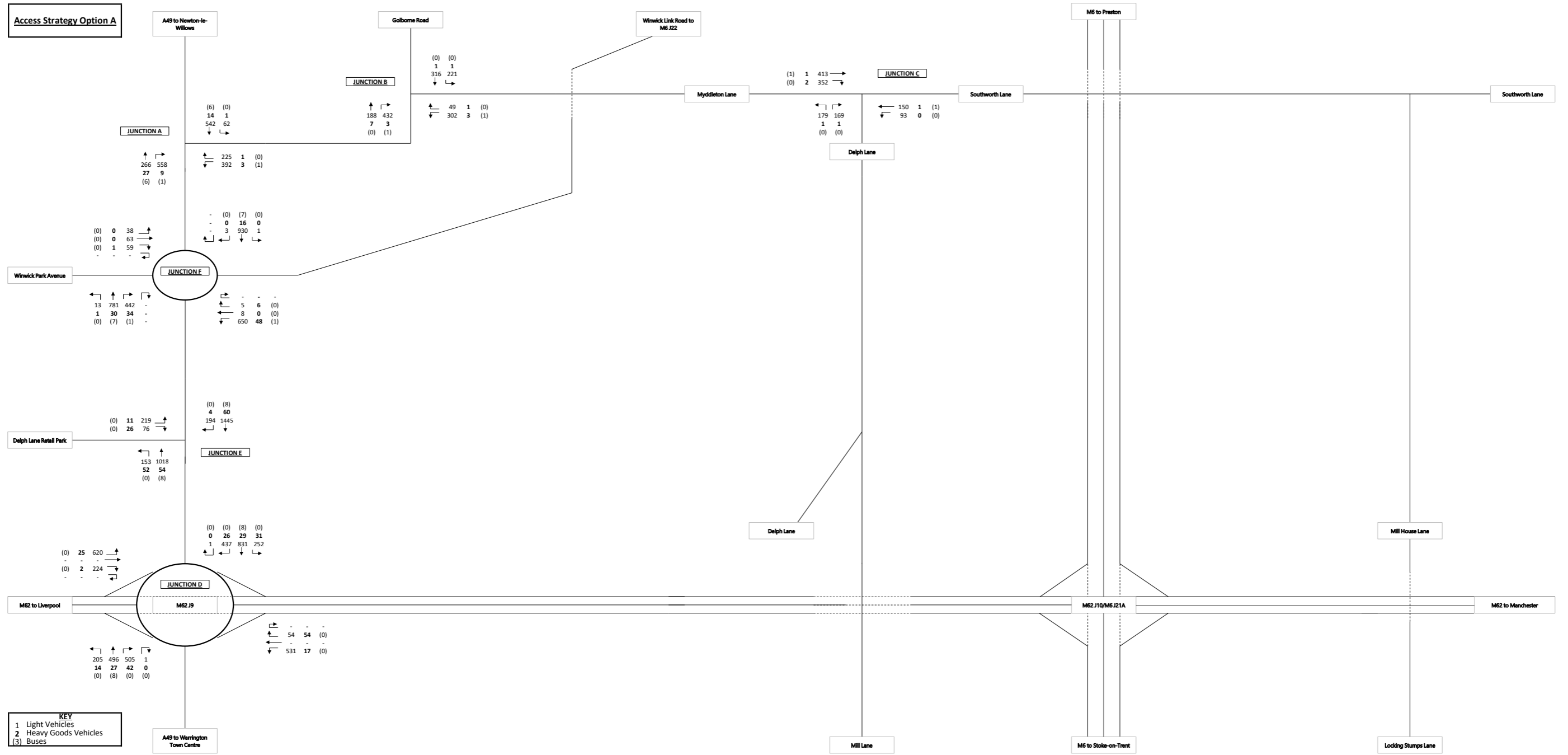

PROPOSED DEVELOPMENT: Peel Hall, Warrington

AM Demand

2018 - Do Minimum (N of M62)

Access Strategy Option A

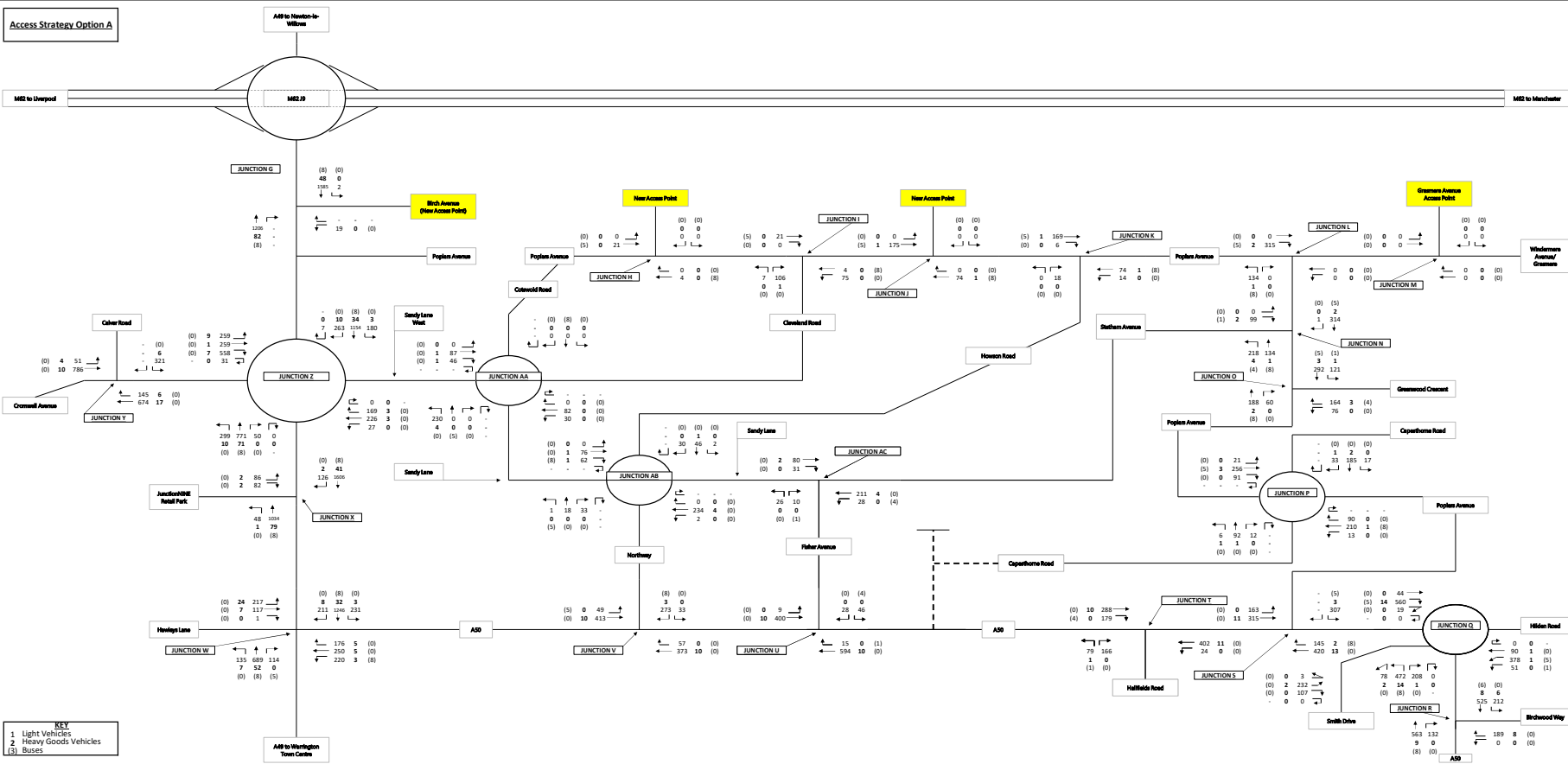

PROPOSED DEVELOPMENT: Peel Hall, Warrington  
AM Demand

2018 - Do Minimum (SW of M62)

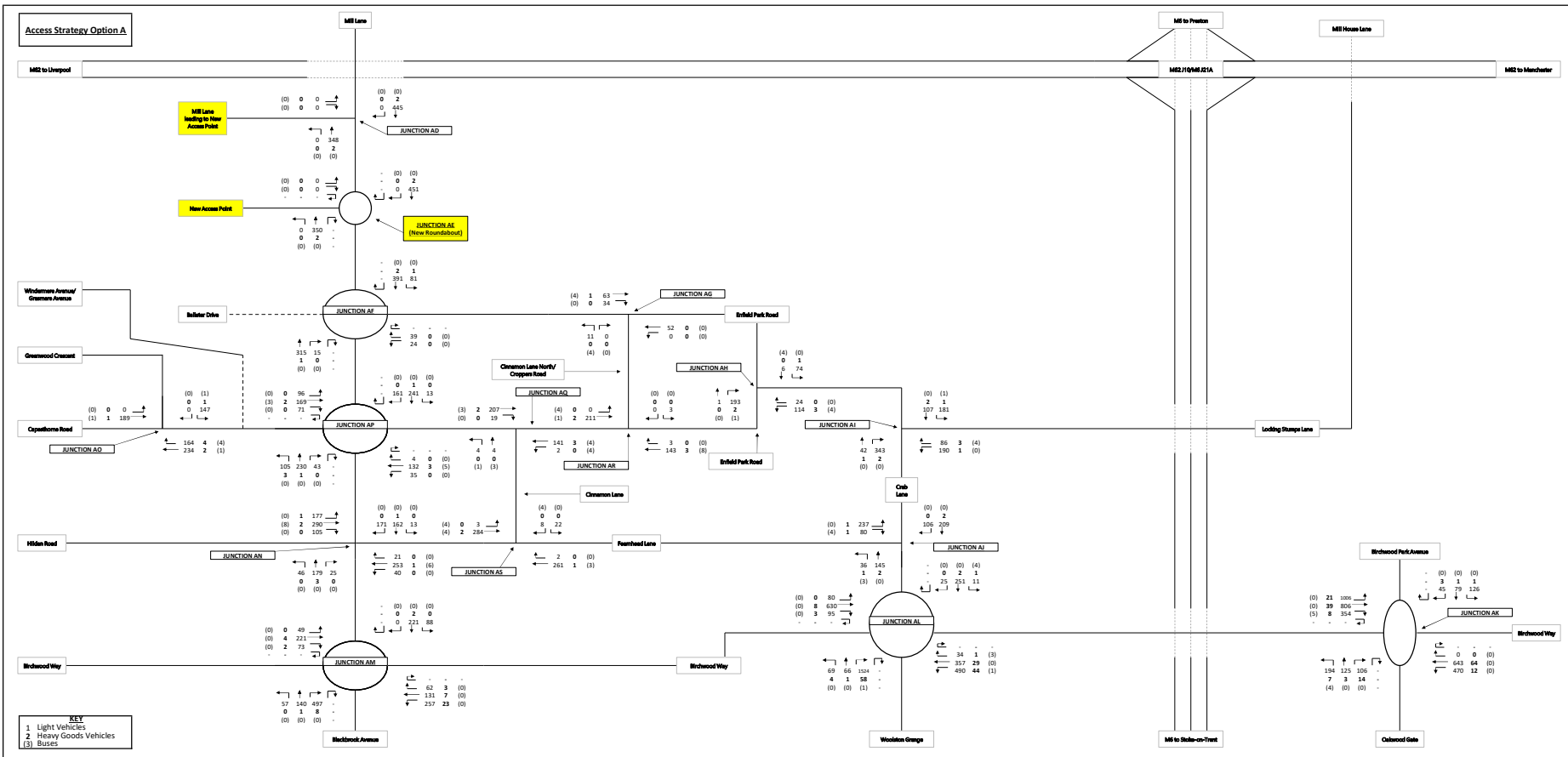

**Access Strategy Option A**

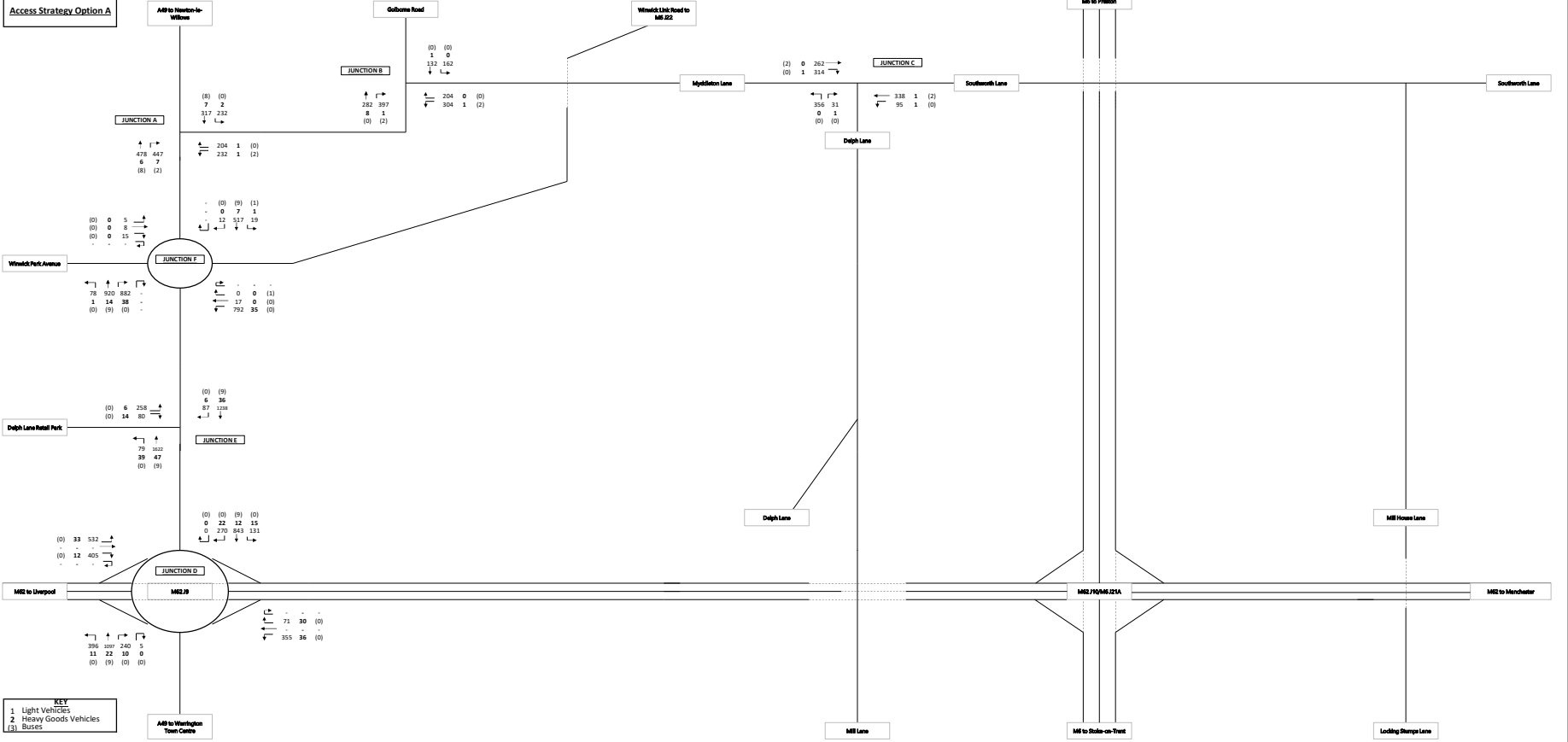

**KEY**  
 1 Light Vehicles  
 2 Heavy Goods Vehicles  
 (3) Buses

PROPOSED DEVELOPMENT: Peel Hall, Warrington  
 PM Demand

2018 - Do Minimum (N of M62)

Access Strategy Option A

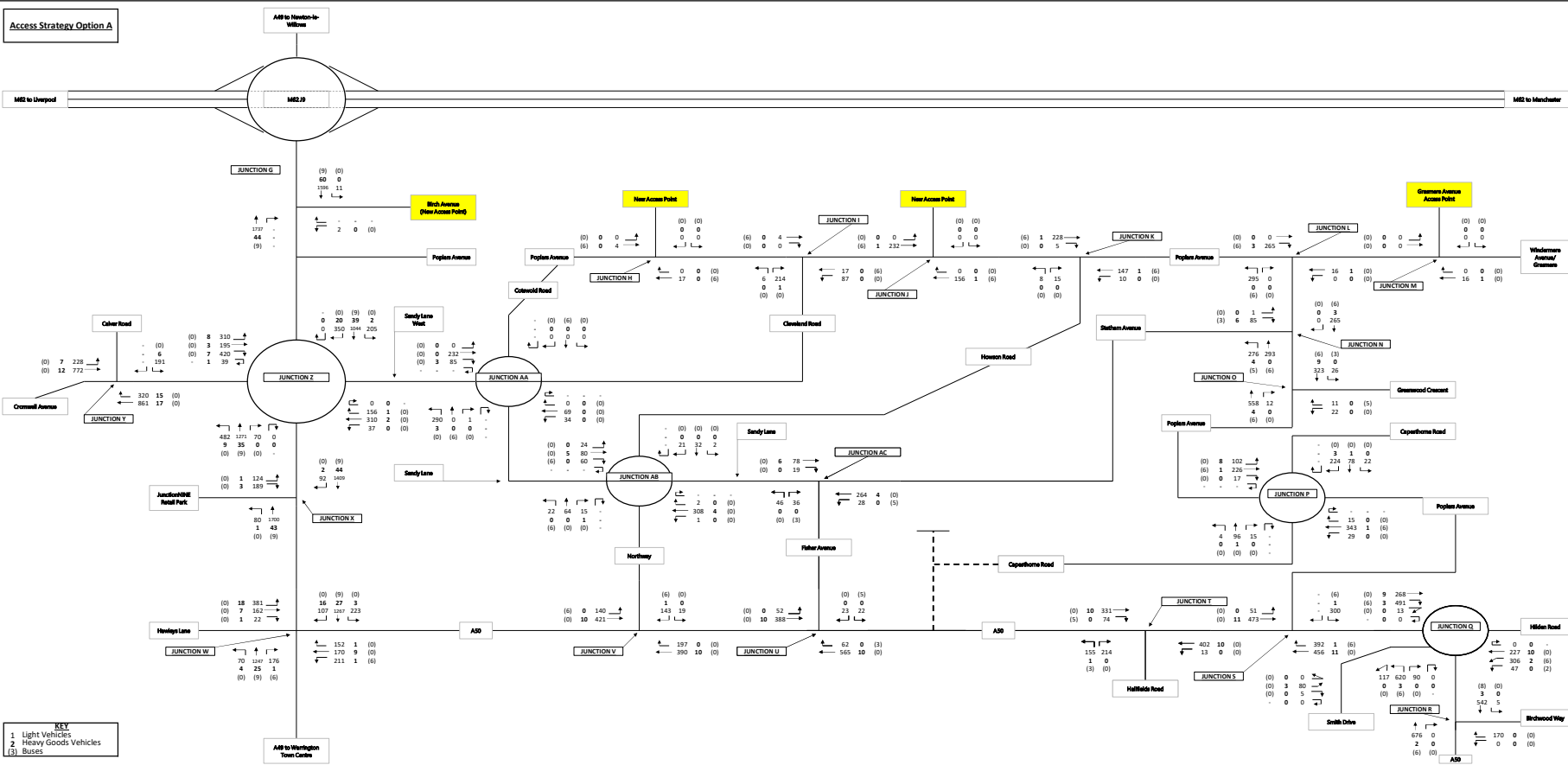

PROPOSED DEVELOPMENT: Peel Hall, Warrington  
PM Demand

2018 - Do Minimum (SW of M62)

